

**ST. LOUIS COUNTY PORT AUTHORITY**

**REQUEST FOR PROPOSALS**

**FOR**

**REPAIR AND REPLACEMENT OF A RETAINING WALL BORDERING  
THE FORMER JAMESTOWN MALL PROPERTY IN ST. LOUIS  
COUNTY**

**Proposals Due:  
June 5, 2023 by 3:00 PM CST  
St. Louis County Port Authority  
Ambassador Kevin O'Malley, Chair  
c/o Sandberg Phoenix & Von Gontard, P.C.  
120 S. Central Ave., Suite 1600  
Clayton, MO 63105  
Attn: Andrew C. Ruben, Esq.**

# **REQUEST FOR PROPOSALS**

## **CONTENTS**

1. Introduction and Terms
2. Scope of Work
3. Contract
4. Instructions to Bidders
5. Terms and Conditions
6. Submission of Bids

### **FORMS & ATTACHMENTS:**

Project Specifications (Appendix A)

Draft Contract (Exhibit 1)

Bid Proposal Form (Exhibit 2)

Prevailing Wage Order (Exhibit 3)

## 1. INTRODUCTION

The St. Louis County Port Authority (the “**Port Authority**”) was established pursuant to Chapter 68 of the Missouri Revised Statutes for the purposes of promoting the general welfare of and within the port district, which includes all of St. Louis County, advancing the economic interests of residents, fostering increased employment opportunities, and promoting trade and industry in St. Louis County, Missouri. The Port Authority is supported by staff from the St. Louis Economic Development Partnership as well as outside consultants and professional service providers.

The Port Authority is the owner of an approximately 140-acre property located at the former Jamestown Mall site in St. Louis County, Missouri 63034 (the “**Property**”). The Property is located at the intersection of N. Lindbergh Blvd (US Highway 67) and Old Jamestown Rd, one mile west of the recently expanded Missouri Route 367. Located at the Southern border of the Property, bordering 14439 Silver Fox Dr., 14449 Silver Fox Dr., and 14434 Silver Fox Dr. is a retaining wall that separates the Property from the neighboring properties. The Port Authority is in need of replacement of the retaining wall and preventative maintenance, as needed (the “**Project**”).

The Port Authority issues this Request for Proposals (the “**RFP**”) from qualified contractors to complete the Project.

## 2. SCOPE OF WORK

Pursuant to this RFP, the Project shall include, and the successful contractor shall provide all labor, equipment, supervision, administration, financing and insurance necessary to perform the work specified in the retaining wall specifications attached hereto as **Appendix A**. This includes but is not limited to: (1) application and issuance of all necessary permits; (2) site preparation; (3) block placement and reinforcement; (4) wall backfill; (5) wall drainage; (6) subsequent protections of wall and fence installation; (7) grading and re-seeding of the neighboring properties, as necessary; and (8) re-installment of any prior guardrails and fencing moved or taken down for construction of the wall.

The Contractor shall at all times observe and comply with all such laws, ordinances, regulations, orders, and decrees, and shall protect and indemnify the Port Authority, St. Louis County, and its representatives against any claim or liability arising from or based on the violation of any such law, ordinance, regulation, order, or decree, whether by itself or its employees.

## 3. CONTRACT

The Port Authority intends to award a lump sum contract, in substantially the form attached hereto as **Exhibit 1** (the “**Contract**”), to the lowest responsible and responsive bidder. The Contract shall not be modified by exceptions noted in any proposals submitted in response to this invitation for bids. **Please note that the Scope of Work and all applicable requirements for the Project are**

**set forth in the RFP and the Exhibits attached hereto.** Each bidder should review and familiarize itself with all provisions and requirements of the Contract, specifically including but not limited to the Scope of Work as set forth herein.

The pricing proposals set forth in the Bid Proposal Form (attached hereto as Exhibit 2) submitted in response to this invitation for bids should cover all of the conditions as set forth in the Contract, precisely as specified and without deviation or alteration of any kind. Submission of a bid in response to this invitation for bids is a firm representation by the bidder that it is prepared to execute immediately the Contract for the Scope of Work, pricing proposal, and schedule set forth in its bid, if and to the extent selected by the Port Authority.

Please be advised that the Project is a ‘public works project’ as defined by applicable Missouri law and is subject to the Missouri Prevailing Wage Law and other state and local laws applicable to public works projects. The Prevailing Wage order is attached as Exhibit 3 hereto. It is the Contractor's responsibility to confirm with the Missouri Department of Labor and Industrial Relations – Division of Labor Standards that the attached applicable Annual Wage Order for St. Louis County remains current as of the date the bid is submitted, and to post all required notices at the job site. Further, it is the Contractor’s responsibility to use its best efforts to provide a preference for the purchase, acquisition, and use of goods, products, materials, etc. produced within the United States, in the performance of this Agreement pursuant to 2 CFR §200.322. The Contractor must comply with Section 6002 of the Solid Waste Disposal Act, as amended by the Resource Conservation and Recovery Act. The requirements of Section 6002 include procuring only items designated in guidelines of the Environmental Protection Agency (EPA) at 40 CFR, 247 that contain the highest percentage of recovered materials practicable, consistent with maintaining a satisfactory level of competition where the purchase price exceeds \$10,000 or the value of the quantity acquired by the preceding fiscal year exceeded \$10,000, procuring solid waste management services in a manner that maximizes energy and resource recovery, and establishing an affirmative procurement program for procurement of recovered materials identified in EPA guidelines. Contractor will follow all environmental requirements, which includes the Clean Air Act (42 U.S.C.A. §7401 et seq.) (“CAA”); Federal Water Pollution Control Act and amendments (33 U.S.C.A. §1251 et seq.) (“Clean Water Act” or “CWA”); and regulations, rules, guidelines, or standards promulgated pursuant to such laws, statute and regulations, as such statutes, regulations, rules, guidelines, and standards, as amended from time to time. Contractor will comply with 40 U.S.C. 3702 and 3704, as supplemented by Department of Labor regulations (29 CFR Part 5). Under 40 U.S.C. 3702 of the Act, Contractor must be required to compute the wages of every mechanic and laborer on the basis of a standard work week of 40 hours. Work in excess of the standard work week is permissible provided that the worker is compensated at a rate of not less than one and a half times the basic rate of pay for all hours worked in excess of 40 hours in the work week. Finally, Contractor will comply with the Davis Bacon Act and Title VI of the Civil Rights Act of 1964 as codified in 42 U.S.C. §2000d et seq. and agrees that it will not use



telecommunications and video surveillance equipment and services as prohibited by 2 CFR §200.216 and §200.471.

#### **4. INSTRUCTIONS TO BIDDERS**

All bids received will be required to include, and will be evaluated based upon, the following:

- a. Experience of Firm and Assigned Personnel. Indicate prior experience of the individual or firm with similar projects. Designate the individual(s) who would have primary responsibility for the Project. Indicate the name, years of service, years of service in particular capacity, and years of experience maintaining similar equipment of personnel to be assigned.
- b. Approach and Timeline. Provide a detailed description of the firm's approach to fulfil the Scope of Work identified herein. The description of the firm's approach should include a detailed timeline.
- c. Approach to Diversity, Equity, and Inclusion. It is the policy of the Port Authority that businesses owned by socially and economically disadvantaged individuals (DBE's) have the maximum opportunity to participate in the performance of contracts financed by the Port Authority. In this regard, the Port Authority has established for the Project a goal of 24% participation by MBE's and 9.5% participation by WBE's in this Project. Bidders should make (and document) their best commercially reasonable efforts to meet these goals if at all possible. A five percent (5%) bid discount shall be applied to MBE bidders during the evaluation process. The bid discount shall lower the eligible MBE bidder's bid but shall not reduce the final contract award amount. In order to qualify for the bid discount, the eligible MBE bidder shall include with its bid a copy of a current MBE certification approval letter issued by a federal, state, or local governmental entity.
- d. Insurance. Proof of proper insurance required as specified in the Contract.
- e. Bid Proposal Form. The Bid Proposal Form (attached as Exhibit 2).

The Port Authority actively encourages submission of proposals from disadvantaged business enterprises and companies owned by minorities, women, immigrants, and veterans. The Port Authority does not discriminate on the basis of race, color, religion, creed, sex, sexual orientation, gender identity, age, ancestry, national origin, disability, or veteran status in consideration of this award.

#### **5. TERMS AND CONDITIONS**

The following terms and conditions apply to all proposals:

1. The Port Authority reserves the right to reject any and all proposals submitted; to select one or more responding parties; to void this RFP and the review process and/or terminate negotiations at any time; to select separate responding parties for various components of the scope of services; and to select a final party/parties from among the proposals received in response to this RFP. Additionally, any and all RFP project elements, requirements and schedules are subject to change and modification. The Port Authority also reserves the unqualified right to modify, suspend, or terminate at its sole discretion any and all aspects of this RFP process, to obtain further information from any and all responding parties, and to waive any defects as to form or content of the RFP or any responses by any party.
2. This RFP does not commit the Port Authority to award a contract, defray any costs incurred in the preparation of a response to this RFP, or contract for any services. All submitted responses to this RFP become the property of the Port Authority as public records. All proposals may be subject to public review, on request, unless exempted as discussed elsewhere in this RFP.
3. By accepting this RFP and/or submitting a proposal in response thereto, each responding party agrees for itself, its successors and assigns, to hold the Port Authority, the St. Louis Economic Development Partnership and its affiliated entities, St. Louis County, and all of their various agents, commissioners, directors, consultants, attorneys, officers and employees harmless from and against any and all claims and demands of whatever nature or type, which any such responding company, its representatives, agents, contractors, successors or assigns may have against any of them as a result of issuing this RFP, revising this RFP, conducting the selection process and subsequent negotiations, making a final recommendation, selecting a responding party/parties or negotiating or executing an agreement incorporating the commitments of the selected responding party.
4. By submitting responses, each responding party acknowledges having read this RFP in its entirety and agrees to all terms and conditions set out in this RFP. Bids shall be open and valid for a period of thirty (30) days from the due date of this RFP.

## **6. TIMELINE AND SUBMISSION OF BIDS**

The deadline to submit questions regarding this RFP is May 29, 2023. All questions shall be submitted via email to Elizabeth Noonan at [bnoonan@ced-solutions.com](mailto:bnoonan@ced-solutions.com), no later than May 29, 2023 at 5:00 p.m. Answers to the questions and any addenda to this RFP will be posted on the Port Authority's website at [www.stlpartnership.com/rfp-rfq/](http://www.stlpartnership.com/rfp-rfq/) under "Notice to Bidders" as available and no later than June 1, 2023.

**To be considered, proposals must be received no later than June 5, 2023, at 3:00 PM CST, at which time said bids will be publicly opened and aloud.**

No award of contract will be made at the bid opening. Depending upon the status of any local, state or federal rules and regulations then in place regarding public gatherings as a result of the Covid-19 pandemic, or in the Port Authority's own judgment, the Port Authority reserves the right

to conduct the public bid opening by video conference and/or provide alternate opportunities and means for bidders to review the submitted bids consistent with applicable state law.

Electronic proposals should be sent by email to [aruben@sandbergphoenix.com](mailto:aruben@sandbergphoenix.com) and [HBean@stlpartnership.com](mailto:HBean@stlpartnership.com).

St. Louis County Port Authority  
Ambassador Kevin O'Malley, Chairman  
c/o Sandberg Phoenix & Von Gontard, P.C.  
Attn: Andrew C. Ruben, Esq.  
120 S. Central Avenue, Suite 1600  
Clayton, MO 63105  
314-435-4909

Please direct inquiries related to this RFP to Elizabeth Noonan at [bnoonan@ced-solutions.com](mailto:bnoonan@ced-solutions.com).

**Appendix A**

See attached.



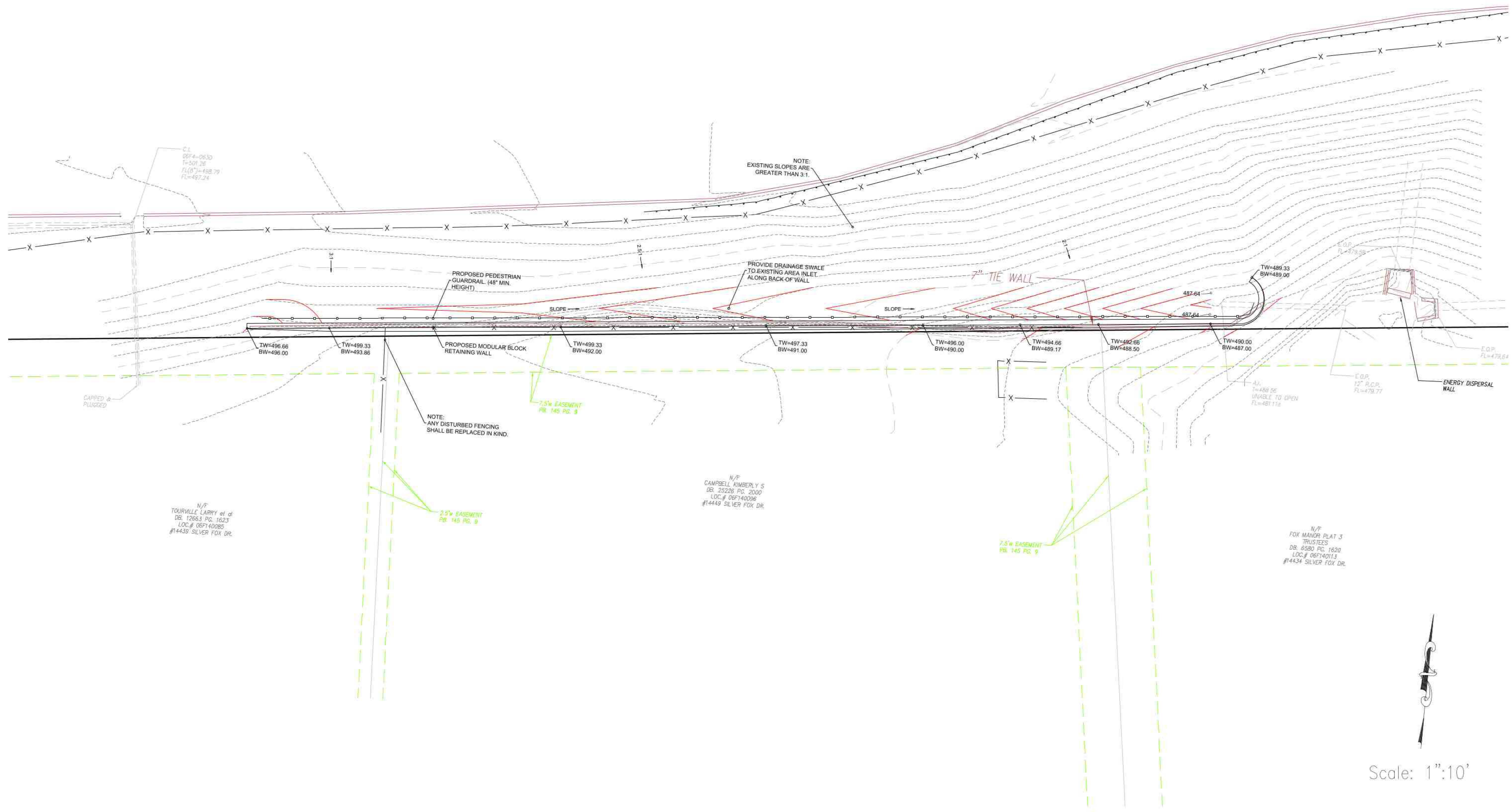

**SURVEY INFORMATION**  
 The survey information depicted hereon was supplied by Stack & Associates in their drawing titled "Wall Design-Base" and emailed on 7/19/22. This information was used in the design of the retaining wall and appurtenances shown hereon, and is reproduced for the reader's understanding of existing and proposed site conditions as developed by others. Midwest Testing and engineer signing and sealing this drawing assume no responsibility for the accuracy of this information including, but not limited to, existing and proposed topography, infrastructure, and improvements. Our use of this information does not constitute our endorsement or approval of this plan.

**NOTIFICATION OF TESTING**  
 It shall be the responsibility of the Contractor to notify the Geotechnical Engineer or testing agency of the need for testing the following work: foundation and leveling pad preparation, geogrid placement, compaction of fill and backfill materials, and drain construction. At a minimum, notification for the testing shall be made by 5:00 p.m. the day before testing is needed. Failure to notify that testing is needed shall not relieve the Contractor of his responsibility to fully comply with these plans and specifications.

**PROTECTION OF WORK**  
 Contractor shall slope the backfill surface away from the wall at the end of each day of work such that surface runoff is directed away from the face of the wall. Contractor shall not allow runoff from adjacent areas to enter the wall construction area.

Scale: 1"=10'

REVISIONS	
NO.	DATE



**Midwest Testing**  
 Geotechnical - Environmental - Materials  
 8606 Page Avenue  
 St. Louis, Missouri 63114  
 314-739-2727 Fax 314-739-5429



**SITE PLAN**  
 Unit Block Retaining Wall  
 Jamestown Mall  
 Florissant, Missouri

JOB NO.	15277
DRAWN BY	KILL
DESIGNED BY	KILL
REVIEWED BY	DJB
DATE	7/29/22

RW-1



**CURVE 1 DATA**  
 R = 5.00'  
 Δ = 75°  
 L = 6.53'

**CURVE 2 DATA**  
 R = 5.00'  
 Δ = 75°  
 L = 6.44'

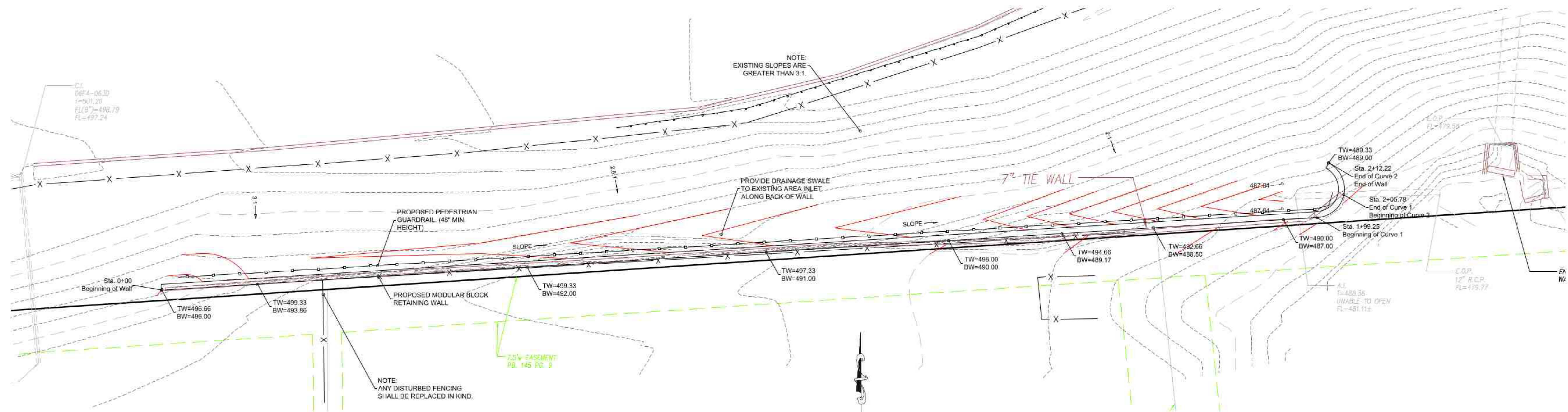

**PLAN VIEW**  
 Scale: 1"=10'

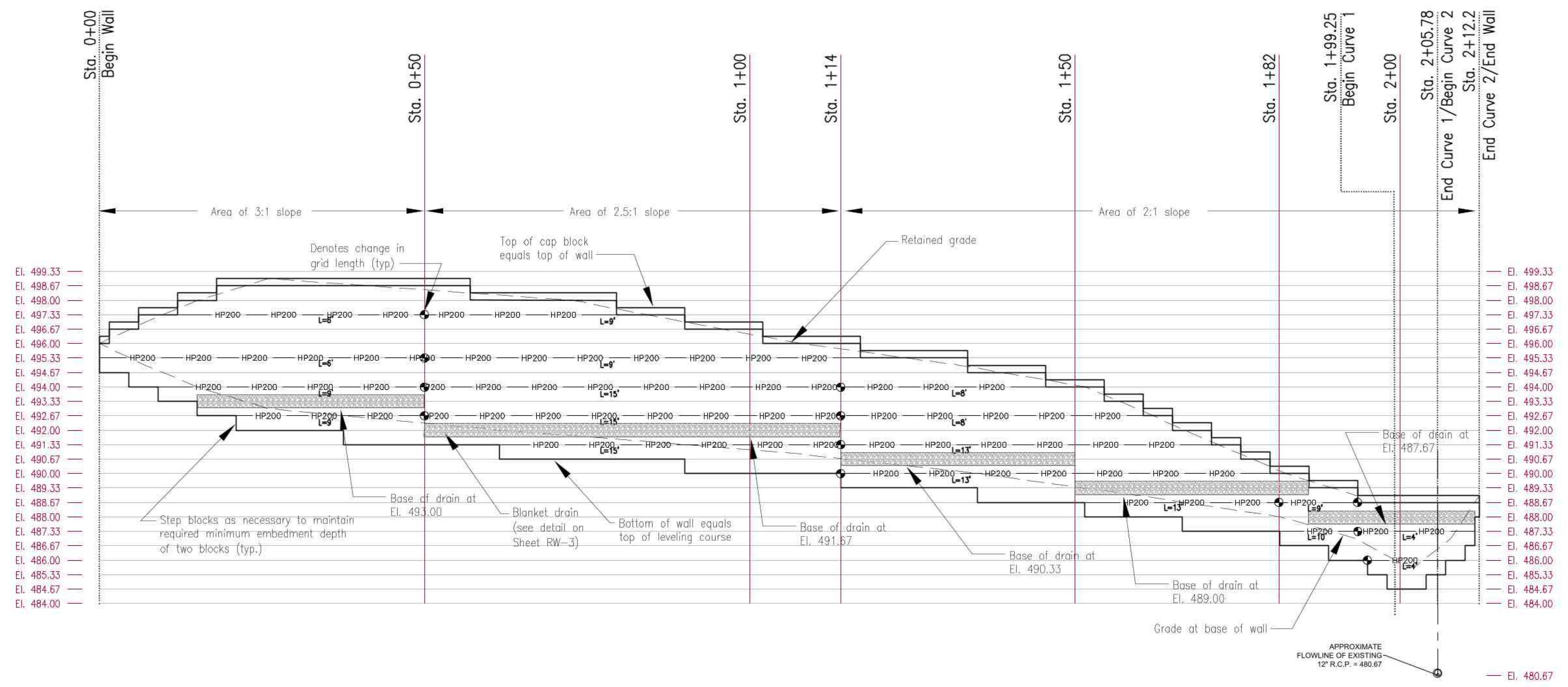

**ELEVATION VIEW**  
 Scales: 1"=10' Horizontal  
 1"=3' Vertical

**LEGEND**  
 — HP200 — Geostar HP200 Geogrid

- NOTES:**
- 1) Secondary geogrid reinforcement for fence and/or guard rail not shown, but required. See details and specifications this plan set, and civil plans for information.
  - 2) Length of geogrid shown measured from back of block. Add for embedment between blocks.
  - 3) Wall stationing is along the base of the wall.

**PROTECTION OF WORK**  
 Contractor shall slope the backfill surface away from the wall at the end of each day of work such that surface runoff is directed away from the face of the wall. Contractor shall not allow runoff from adjacent areas to enter the wall construction area.

**NOTIFICATION OF TESTING**  
 It shall be the responsibility of the Contractor to notify the Geotechnical Engineer or testing agency of the need for testing the following work: foundation and leveling pad preparation, geogrid placement, compaction of fill and backfill materials, and drain construction. At a minimum, notification for the testing shall be made by 5:00 p.m. the day before testing is needed. Failure to notify that testing is needed shall not relieve the Contractor of his responsibility to fully comply with these plans and specifications.

**DISCLAIMER OF RESPONSIBILITY**  
 I hereby specify that the documents intended to be authenticated by my seal are limited to this sheet. Copies have been retained by the professional engineer. I hereby disclaim any responsibility to subsequent changes to this drawing and all other drawings, specifications, estimates, reports, or other documents or instruments relating to or intending to be used for any part of the architectural or engineering project or survey unless the changes are made by me or with my written permission.

**SURVEY INFORMATION**  
 The survey information depicted hereon was supplied by Stock & Associates in their drawing titled "Wall Design-Base" and emailed on 7/19/22. This information was used in the design of the retaining wall and appurtenances shown hereon, and is reproduced for the reader's understanding of existing and proposed site conditions as developed by others. Midwest Testing and the engineer signing and sealing this drawing assume no responsibility for the accuracy of this information including, but not limited to, existing and proposed topography, infrastructure, and improvements. Our use of this information does not constitute our endorsement or approval of this plan.

REVISIONS	
NO.	DESCRIPTION



**Midwest Testing**  
 Geotechnical/Environmental/ Materials  
 8606 Page Avenue  
 St. Louis, Missouri 63114  
 314-739-2727 • Fax 314-739-5429



**PLAN & ELEVATION VIEWS**  
 Unit Block Retaining Wall  
 Jamestown Mall  
 Florissant, Missouri

JOB NO.	15277
DRAWN BY	KILL
DESIGNED BY	KILL
REVIEWED BY	DJB
DATE	7/29/22

RW-2



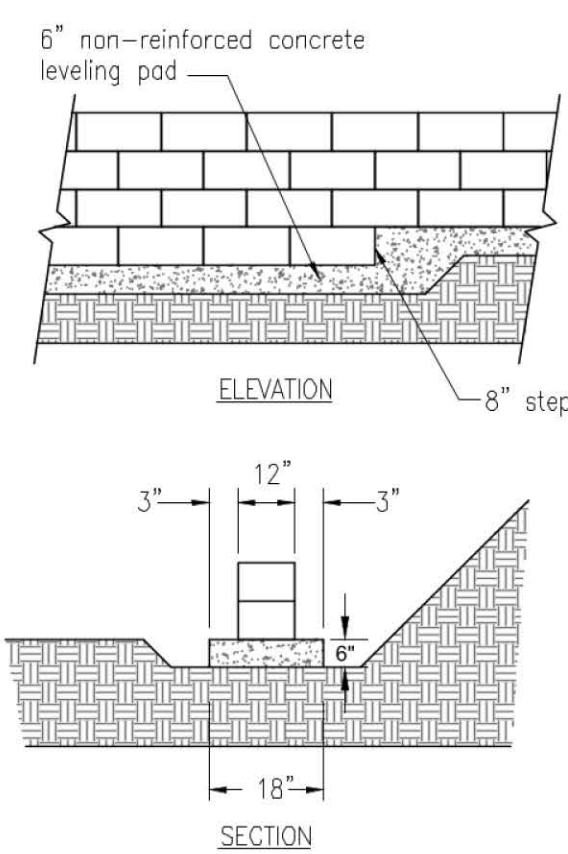

**LEVELING PAD DETAIL - NON-REINFORCED CONCRETE**  
N.T.S.

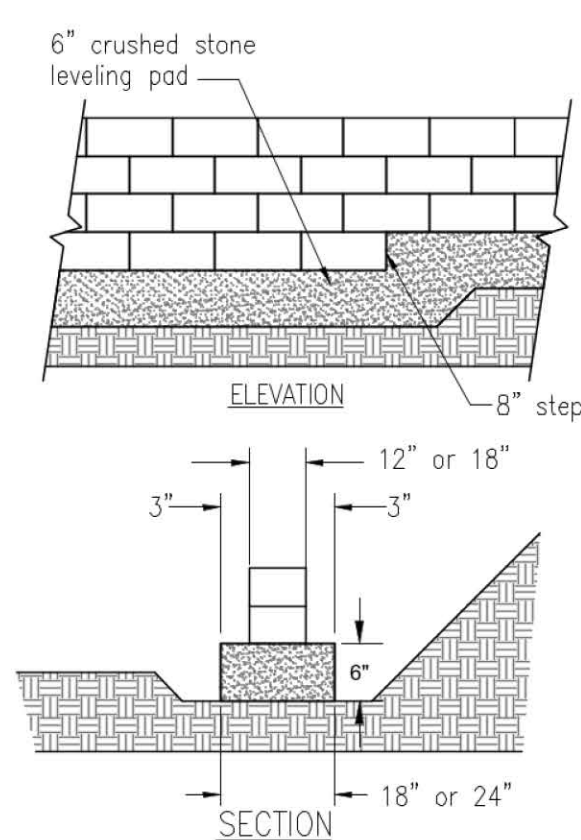

**LEVELING PAD DETAIL - CRUSHED STONE**  
N.T.S.

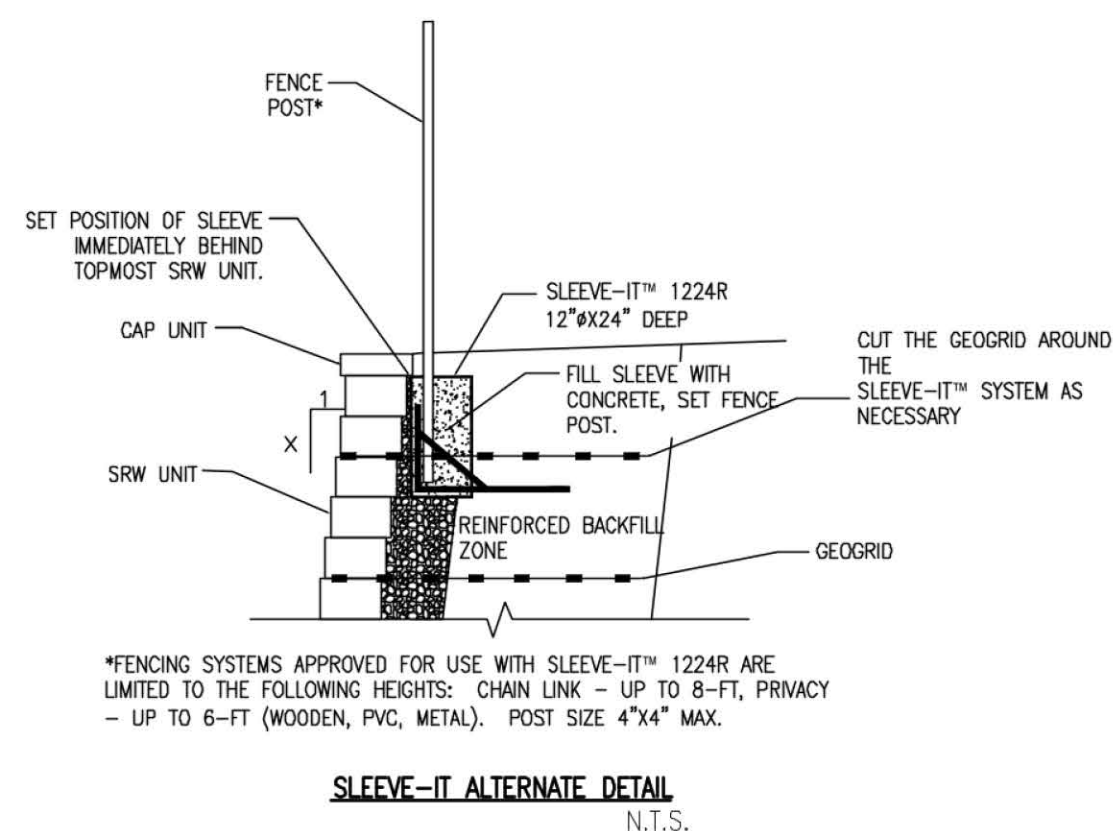

**SLEEVE-IT ALTERNATE DETAIL**  
N.T.S.

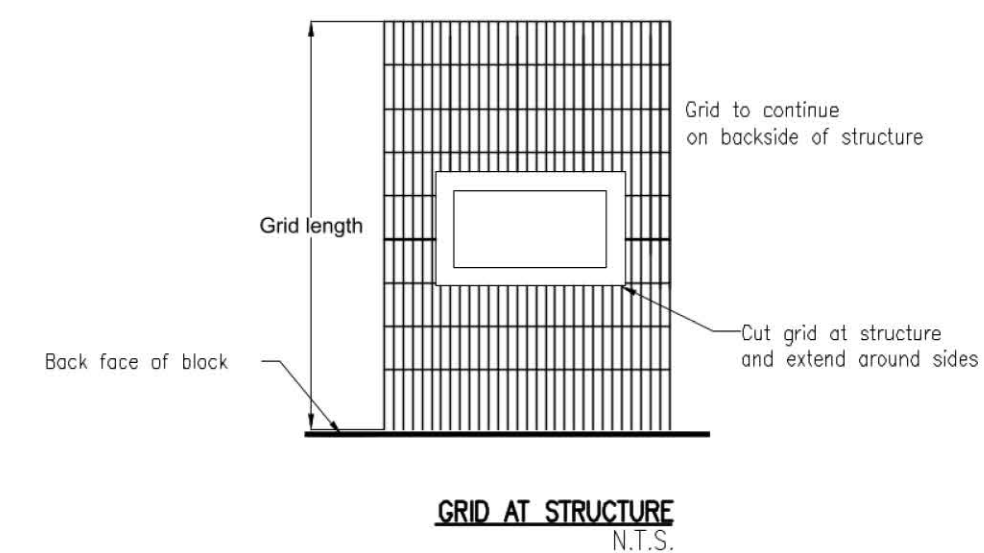

**GRID AT STRUCTURE**  
N.T.S.

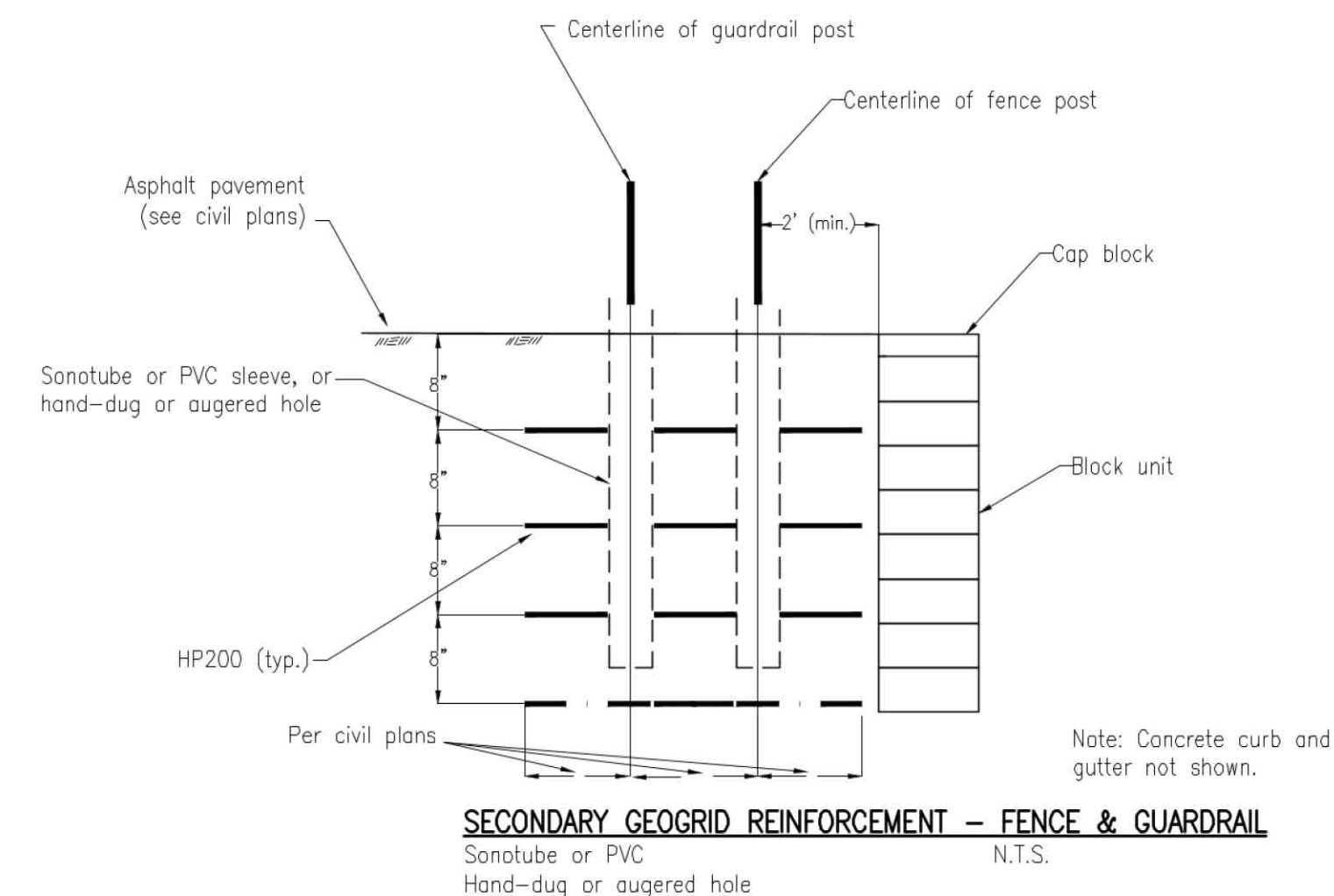

**SECONDARY GEOGRID REINFORCEMENT - FENCE & GUARDRAIL**  
N.T.S.

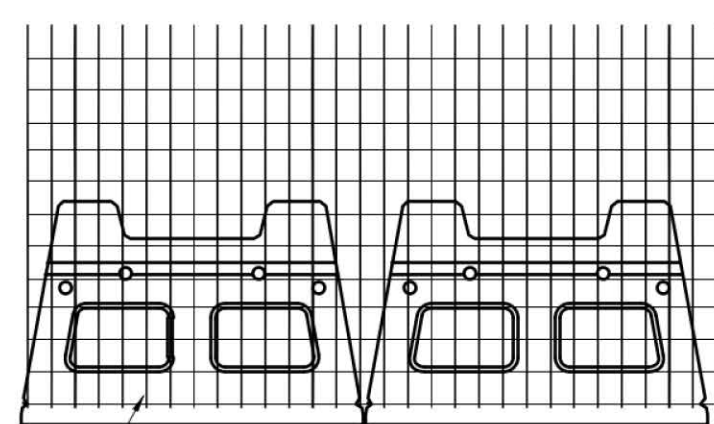

**GRID & PIN CONNECTION**  
N.T.S.

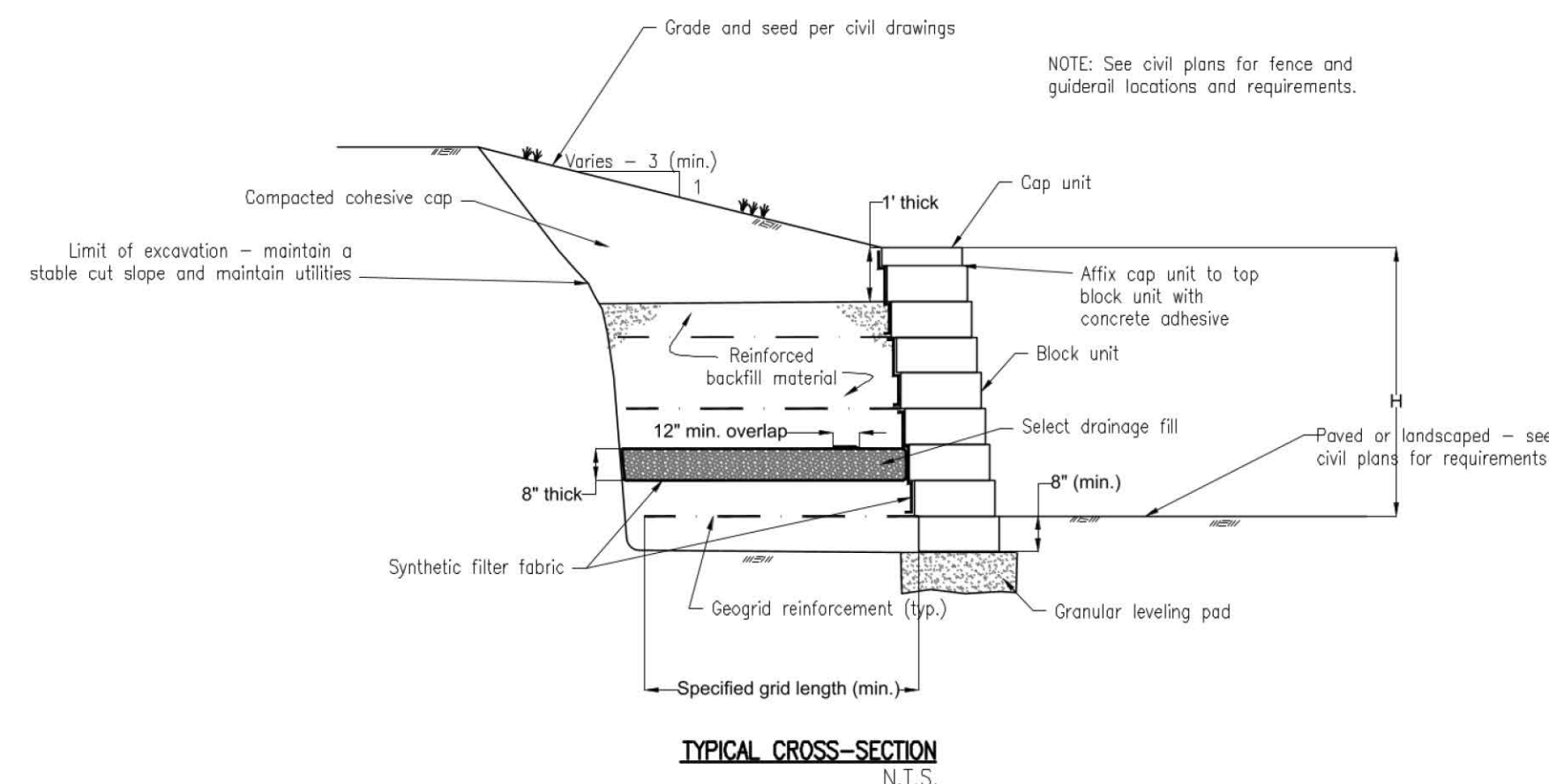

**TYPICAL CROSS-SECTION**  
N.T.S.

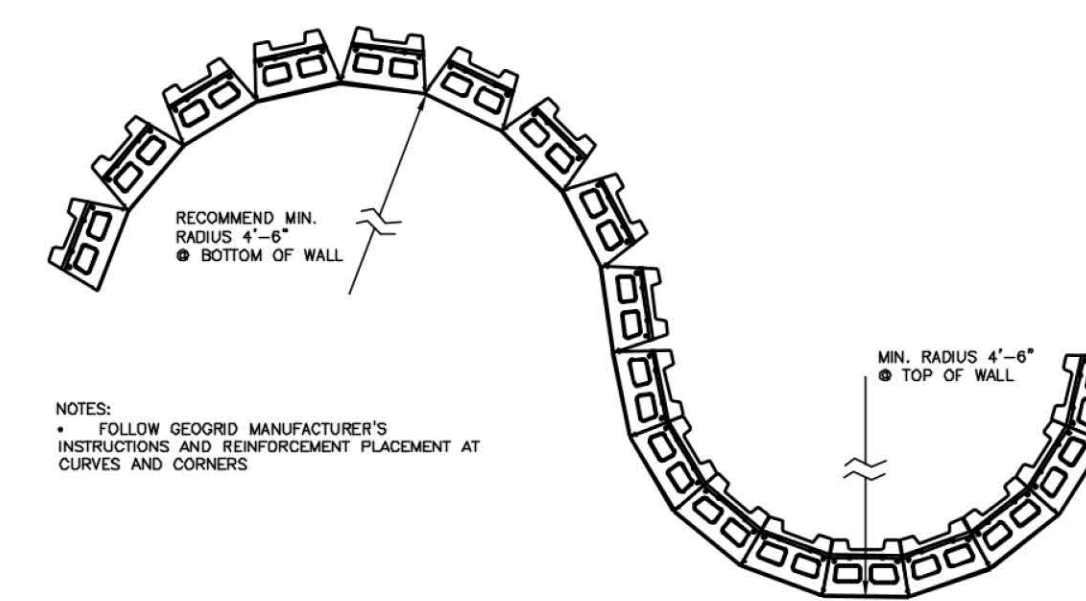

**SQUARE FOOT UNIT - CURVE DETAILS**  
N.T.S.

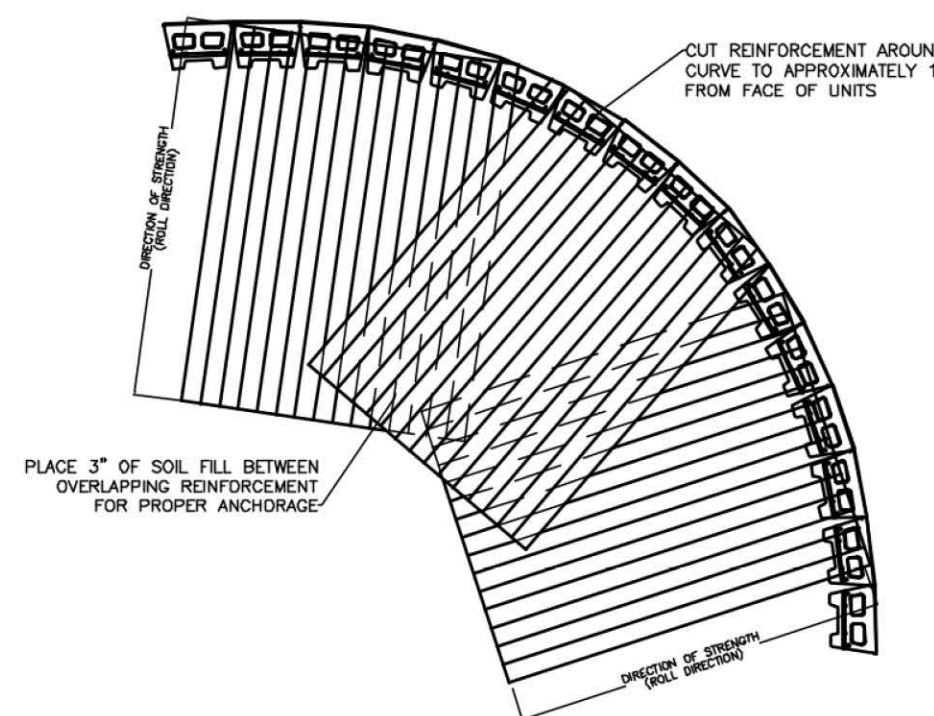

**GRID PLACEMENT ON CURVES**  
N.T.S.

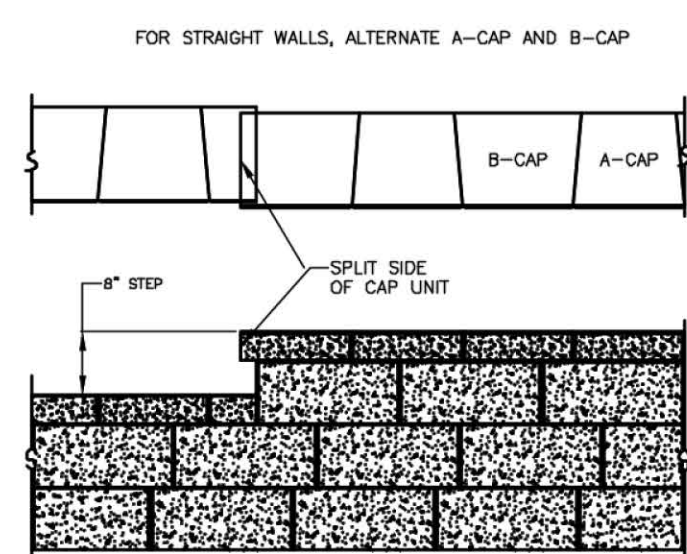

**CAPPING DETAIL - PROFILE**  
N.T.S.

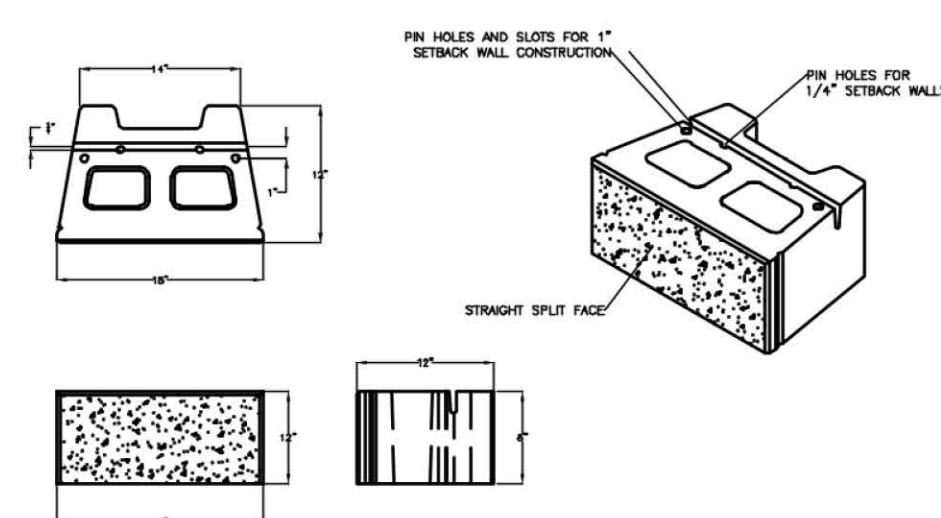

**VERSA-LOK SQUARE FOOT BLOCK DETAILS**  
N.T.S.

REVISIONS	
NO.	DESCRIPTION



**Midwest Testing**  
Geotechnical - Environmental - Materials  
8606 Page Avenue  
St. Louis, Missouri 63114  
314-739-2727 Fax 314-739-5429



**DETAILS**  
Unit Block Retaining Wall  
Jamestown Mall  
Florissant, Missouri

JOB NO.	15277
DRAWN BY	KLL
DESIGNED BY	KLL
REVIEWED BY	DJB
DATE	7/29/22

RW-3



REFERENCES

The following references are applicable to the work:

- ACI 304 Recommended Practice for Measuring, Mixing, Transporting, and Placing Concrete
ACI 306R Cold Weather Concreting
ASTM C 33 Concrete Aggregates
ASTM C 94 Ready-mixed Concrete
ASTM C 150 Portland Cement
ASTM C 260 Air Entraining Admixtures for Concrete
ASTM C 494 Chemical Admixtures for Concrete

PRODUCTS

Retaining wall units shall be Versa-Lok 8-inch-high Square Foot units. Cap units shall be Versa-Lok 4-inch-high Cap Units for Square Foot blocks. All wall and cap units shall be by Versa-Lok Retaining Wall Systems (www.versa-lok.com).

Square Foot units are 8 inches high by 18 inches wide by 12 inches deep and weigh approximately 85 pounds each. Block color and finish shall be as specified by Owner. The units shall conform to ASTM C 145 with a minimum unit weight of 125 pounds per cubic foot. Pins shall be Versa-Tuff pins as supplied with Versa-Lok units. Material shall be protected at the job site and kept free from damage prior to installation.

The foundation leveling course material shall conform to the requirements of Missouri Type 5 Aggregate crushed stone as set forth in Section 1007 of Missouri Standard Specifications for Highway Construction. MoDOT Class B concrete can be used as a leveling course alternative.

The reinforced wall backfill shall be 1-inch minus crushed stone.

The select drainage fill and block core fill shall be Missouri Grade 4 Drainage Aggregate. Material locally referred to as 3/4- or 1-inch clean crushed stone shall be acceptable, provided it contains less than 5 percent by weight passing the No. 200 sieve.

The cohesive soil cap shall consist of cohesive soil with a liquid limit not to exceed 45 and a plasticity index (PI) less than 20. The material shall be free of rubble, boulders, cobbles, and gravels, and not contain more than 5 percent by weight organic matter.

The synthetic filter fabric shall be an 8-ounce nonwoven fabric such as Mirafix 140N or equivalent

Adhesive cement shall be Versa-Lok Concrete Adhesive or equivalent.

Geogrid reinforcement shall be GeoStar HP200, manufactured by U.S. Fabrics, and as shown on the drawings.

Fences and guard rails shall be as specified on the civil drawings or by Owner.

Equivalent products will be considered only upon written request to the Engineer prior to bidding, including submittal of product specifications and test data satisfactory to the Engineer.

WALL ERECTION

Site Preparation. Vegetation and topsoil shall be removed from all retaining wall construction areas.

Bench into existing overburden as needed to permit the placement of the specified geogrid reinforcement length.

Should durable rock be encountered above proposed reinforcement elevations, the Geotechnical Engineer shall be notified immediately.

If soft soils or loose fills are encountered, these materials shall be removed to expose a suitable bearing material approved by the Geotechnical Engineer.

Open excavations shall be observed by the Engineer prior to starting wall construction to verify that the desired bearing stratum is exposed and the base of the excavation is free of loose soil, uncompacted fill, water, frozen material, and deleterious matter. Undercut areas shall be filled with compacted material in accordance with compaction requirements set forth elsewhere in these specifications.

Contractor shall maintain stable cut slopes and excavations at all times, including compliance with applicable codes and regulations. The installation of temporary shoring (if needed) is the responsibility of the Contractor. The Contractor shall protect existing utility poles against movement until the wall construction is completed.

Filling and Compaction

Compaction of grade-raise fills and backfill shall achieve at least 95% of the material's standard Proctor (ASTM D 698) maximum dry density at a moisture content conducive to achieving compaction and maintaining a stable fill surface.

Block Placement

Leveling pad material shall be placed with a minimum thickness of 6" and extend laterally a minimum of 3" in front and behind the modular wall unit. Leveling course shall be compacted to at least 95% of standard Proctor. As an alternate, concrete can be used to construct the leveling pad. Leveling pad shall be prepared to ensure full contact to the base surface of the wall units.

The minimum embedment depth is 8" below grade (one block course). Block units shall be stepped as required to remain at least the minimum embedment depth below grade at all locations.

Install first course of wall units at the minimum embedment depth on the prepared leveling course. Alignment and level shall be checked in all directions and all units shall be in full contact with the base and properly seated. To ensure that the units are properly aligned, a thin veneer of fine- to medium-grained sand not to exceed 1 inch in thickness may be spread over the prepared footing to aid in leveling and provide full contact with the prepared footing.

Sweep all excess material from top of units and install next course in running bond pattern. Install two pins per unit, ensuring that the pin protrudes fully into the lower course. See specifications elsewhere on this sheet for geogrid installation procedures. Maximum stacked vertical height of wall units, prior to block core fill and backfill placement and compaction, shall not exceed three courses.

The setback of successive courses shall be 'zero' with the blocks installed in the near-vertical position, resulting in a very slight wall batter of 0.9 degrees. Layout of curves and corners shall be in accordance with manufacturer's recommendations, as shown on the detail drawings.

The walls shall be fitted with 4-inch-high cap units. Cap units shall be affixed with the adhesive cement applied at the manufacturer's recommended rate. All elevations shown are finished grade and shall be within 0.1 feet of those shown on the grading plan.

If cutting is necessary, use brick chisel and split unit in half or use half-blocks as provided by the manufacturer. Pieces less than one-half of the original unit size shall not be used.

Geogrid Reinforcement

Refer to the construction drawings for required length and elevation of geogrids. Geogrids can have a minimum tolerance of the specified length minus 3 inches. Lengths shorter than this minimum will be rejected. Additional geogrid length must be added for embedment between block courses.

The placement of the geogrids is shown on the construction drawings. Monitoring of the fill will be necessary to ensure that the geogrids are placed at the specified elevation. Geogrids placed outside of a plus or minus 4-inch zone of the geogrid design elevation will not be accepted. Removal of unacceptably placed geogrids will be required so that proper elevations can be obtained for the placement of the geogrids.

Geogrid is to be laid horizontally on compacted backfill and oriented with the highest strength axis perpendicular to the wall alignment. The geogrid must be connected to the wall units by embedding the geogrid between the block courses and installing the block pins through the openings in the geogrid. The geogrid must be anchored and pulled taut before the backfill is placed over the geogrid.

Geogrid reinforcements shall be continuous throughout their embedment lengths and placed side-by-side to provide 100% coverage at each level. Spliced connections between shorter pieces of geogrid or gaps between adjacent pieces of geogrid are not permitted. Adjacent geogrid layers must overlap at curves and corners.

Slack in the geogrid at the wall unit connections shall be removed in the manner and degree established by the Engineer during construction of the wall. It is recommended that a tensioning device or metal forks be used to provide uniform tensioning of all grids throughout the height of the wall.

Slack in the geogrids will result in undesirable movements of the wall which will require repair by the Contractor at no expense to the Owner.

See specifications elsewhere on this sheet for secondary geogrid at fence and guardrail locations.

Wall Backfill

Place reinforced wall backfill material in maximum 8" thick loose lifts and compact to at least 95% of the material's maximum dry density, as determined by the standard Proctor (ASTM D 698) method. The moisture content of the backfill material must be within the range conducive for achieving the required compaction, which may require aeration or the addition of water depending on the moisture conditions prevailing at the time of construction.

Backfill shall be placed, spread, and compacted in such a manner that minimizes wrinkles and movement of the geogrid. Backfill shall be placed from the wall outward to ensure that the geogrid remains taut during the backfilling operation.

Field density testing shall be conducted by a qualified soils technician to verify that at least the minimum degree of compaction is being obtained during the backfill placement. All soils tests shall be conducted by the Geotechnical Engineer concurrent with the grading and backfilling operations.

Wall Drainage

Install the blanket drains for the length of the walls as shown on the wall elevation views and detail drawings. At least a portion of the blanket drain shall be installed above the grade at the base of the wall. Install synthetic filter fabric (around the 8" thick layer of select drainage fill and along the back face of the wall as shown on the plans) as construction proceeds to prevent the migration of soil fines into the drainage material and through the block joints.

Positive contact between the drainage blanket and the back face of the wall blocks shall be established. A minimum of 3" of reinforced backfill shall be present between the fabric-wrapped blanket drain and any geogrid layer.

Finished grading shall be performed such that surface water will sheet-flow along the back of the wall, as shown on the drawings. Grade and seed or sod per civil drawings. Re-grade and dress any eroded areas within the work area.

Utility Installation

All utilities must be installed such that they do not interfere with or damage the wall reinforcement. Utilities located within the reinforced backfill zone of the retaining walls shall be installed concurrently with the reinforced fill.

Reinforcing material at any elevation conflicting with a utility line shall be installed at the required elevation and extend the required distance from the face of the wall. However, if the reinforcing material is displaced less than 6" in the vertical direction at the point of conflict only, the reinforcing material shall travel over or under the utility line without being cut. Install a minimum of 3" of compacted fill between the utility line and the reinforcing layer. If the vertical displacement required to install the reinforcing material is greater than 6", an opening shall be cut in the reinforcing material to allow the utility to pass through. The opening shall be a maximum of 2" larger than the utility that passes through.

It is recommended that all excavations above the reinforced zone be performed using a smooth-bottom bucket to minimize the damage to the reinforcing materials.

Should concrete flumes or storm water pipes penetrating the face of the wall be proposed in the future, it is recommended that the Geotechnical Engineer shall be contacted to review these changes to assess their impact on the retaining walls.

NOTIFICATION OF TESTING

It shall be the responsibility of the Contractor to notify the Geotechnical Engineer or testing agency of the need for testing the following work: foundation and leveling pad preparation, geogrid placement, compaction of fill and backfill materials, and drain construction. At a minimum, notification for the testing shall be made by 5:00 p.m. the day before testing is needed. Failure to notify that testing is needed shall not relieve the Contractor of his responsibility to fully comply with these plans and specifications.

DISCLAIMER OF RESPONSIBILITY

I hereby specify that the documents intended to be authenticated by my seal are limited to this sheet. Copies have been retained by the professional engineer. I hereby disclaim any responsibility to subsequent changes to this drawing and all other drawings, specifications, estimates, reports, or other documents or instruments relating to or intending to be used for any part of the architectural or engineering project or survey unless the changes are made by me or with my written permission.

PROTECTION OF WORK

Contractor shall slope the backfill surface away from the wall at the end of each day of work such that surface runoff is directed away from the face of the wall. Contractor shall not allow runoff from adjacent areas to enter the wall construction area.

As-built Construction Tolerances

Vertical alignment: ± 1 1/2" over any 10' distance.

Horizontal alignment: ± 1 1/2" over any 10' distance.

Wall Batter: 0.9° ± 1'

Corners and bends: ± 1' to theoretical location.

Maximum horizontal gap between erected units shall be 1/2".

Subsequent Protection of Wall

The design of the wall is based on conditions and loads imposed on the wall upon completion of the project. Prior to project completion, the wall is vulnerable to damages caused by construction activity adjacent to the wall. Of particular concern is the use of grading equipment on the retained fill at the top of the wall.

Only equipment with a weight not exceeding 1 ton can be used in the 3' zone immediately behind the back face of the wall blocks. Equipment exceeding this weight limit, including, but not limited to, compaction equipment, scrapers, high-lifts, dozers, skid-steers, backhoes, motor graders, dump trucks, and pavers, must be kept a minimum of 3' from the back face of the wall blocks to avoid overstressing the geogrids and pushing the wall out of alignment. This restriction may require the use of hand labor to complete the wall.

Do not allow traffic and equipment to operate at an angle to the wall. Traffic and equipment which do not travel parallel to the wall can impart dynamic forces to the wall which can move the wall out of proper alignment. Any damage to the wall caused by the Contractor shall be repaired by the Contractor at no cost to the Owner.

The surface of the wall backfill shall be graded at the end of each day of work to provide positive surface drainage away from the wall. Grading shall include proper contouring of fills in adjacent areas to prevent the flow of surface water into the select backfill work area.

Uncontrolled infiltration from heavy rains during construction can cause severe erosion and undermining of unit block walls, requiring their removal and reconstruction in some instances. Care must be exercised during construction to prevent the infiltration of surface water into the work area behind the wall. The Contractor shall control surface water during wall construction and make all necessary repairs caused by surface water at no additional expense to the Owner.

Fence Installation

Secondary reinforcement is to be installed continuously along the length of the fences and guardrails as shown on the detail drawings. Secondary reinforcement consists of four layers of GeoStar HP200, 4 feet wide, spaced at 8-inch vertical intervals.

As an alternate for fence and guardrail post installation, post locations can be fitted with Sonotubes, PVC sleeves, or the 12" diameter Sleeve-It 1224R system. As an alternate for guardrail installation, the Sleeve-It 1632R system can be installed at guardrail post locations. If selected, these alternates must be installed concurrent with geogrid installation and backfill placement.

Fences and guardrails shall be installed per the manufacturer's guidelines.

GENERAL NOTES

- 1) Identifying and protecting underground utility locations shall be the responsibility of the Contractor. Underground utilities, if present, shall be located prior to excavation, grading, and wall construction.
2) Notify the Engineer immediately if running water is encountered. Do not proceed with work until method of dealing with rock or running water is approved.
3) The Contractor shall obtain and pay for all permits which may be required for this project.
4) It shall be the responsibility of the Contractor to provide and preserve all survey stakes during construction.
5) Care shall be taken to prevent damage to edges of existing pavement, curbs, and structures. Damaged pavement, curbs, and structures shall be repaired or replaced as directed by the Owner.
6) Fill where necessary to establish the required grades for the wall construction. All fills shall be placed in maximum 8-inch-thick loose lifts and mechanically compacted as specified herein, at a moisture content conducive to achieving the required compaction criterion.
7) All disturbed areas shall be finish-graded, raked, and vegetated, or paved to prevent soil erosion of exposed ground surfaces.
8) Provide siltation control, and keep streets and adjacent properties clean and free of dirt, mud, and debris in accordance with applicable regulations.
9) The surface of the wall backfill shall be graded at the end of each day of work to provide positive surface drainage away from the walls. Grading shall include proper contouring of fills in adjacent areas to prevent the flow of surface water into the select backfill work area. Uncontrolled infiltration from heavy rains during construction can cause severe erosion and undermining of unit block walls, requiring their removal and reconstruction in some instances. Care must be exercised during construction to prevent the infiltration of surface water into the work area behind the walls.
10) Changes to any aspect of the design depicted on the plans, including, but not limited to, the length, elevation, and type of geogrid, backfill material, and block face units, shall not be made without the written permission of Midwest Testing.
11) Drawings will not be to scale if reduced or enlarged. Use dimensions and elevations.
12) Maintain stable cut slopes and protect existing utilities during construction.
13) The existing locations, elevations, grades, and alignments are based on drawings produced by Cochran.
14) Block course, geogrid, and blanket drain elevations and dimensions as shown in the drawings are based on construction using 8-inch-high block units.

RETAINING WALL DESIGN

The following parameters and requirements were used in the development of the designs depicted hereon

Table with 4 columns: Component, Total Unit Weight,pcf, Cohesion,psf, Friction Angle (θ). Rows include Reinforced compacted wall fill, Retained fill, Foundation Soil, Internal Stability of Wall, and External Stability of Wall.

Table with 2 columns: External Stability of Wall, Factor of safety for direct sliding, Factor of safety for overturning, Maximum eccentricity (e/L ratio).

External Loading
Surcharge load = 150 psf for paved areas; 100 psf for landscaped areas

Bearing Conditions
All walls shall bear on natural undisturbed soil. The design of the walls includes a factor of safety of at least 2 against a general bearing capacity failure.

Global Stability
These walls have been designed with a static factor of safety of at least 1.5 for global stability.

Table with 2 columns: REVISIONS, NO., DATE, DESCRIPTION.

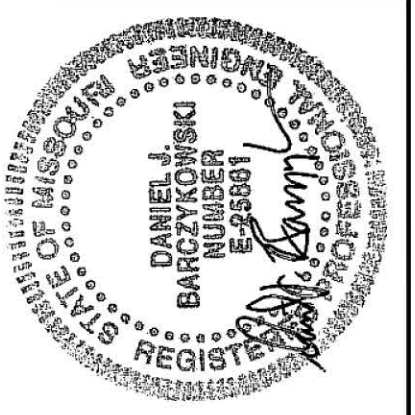

Midwest Testing
Geotechnical/Environmental Materials
8606 Page Avenue
St. Louis, Missouri 63114
314-739-2727 Fax 314-739-5429

SPECIFICATIONS
Unit Block Retaining Wall
Jamestown Mall
Florissant, Missouri

Table with 2 columns: JOB NO., 15277; DRAWN BY, KLL; DESIGNED BY, KLL; REVIEWED BY, DUB; DATE, 7/29/22.

RW-4



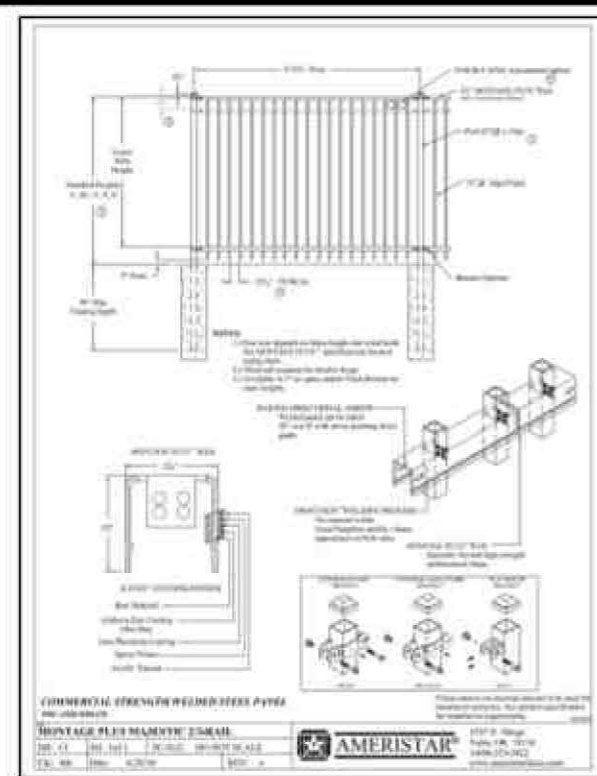

**PEDESTRIAN GUARDRAIL/FENCE DETAIL**  
(n.t.s.)  
(48" HEIGHT @ TOP OF RETAINING WALL)

FENCE/PEDESTRIAN GUARDRAIL SHALL BE AMERSTAR COMMERCIAL STRENGTH FENCE OR EQUIVALENT.

- RETAINING WALL NOTES:**
- 1.) ALL CONSTRUCTION SHALL BE PER THE MANUFACTURERS RECOMMENDATION.
  - 2.) SHOP DRAWINGS BEARING THE SEAL OF A REGISTERED ENGINEER IN THE STATE OF MISSOURI TO BE SUPPLIED TO THIS ENGINEER FOR APPROVAL.
  - 3.) WALL SYSTEM FACE AND COLOR SHALL BE ACCEPTED BY OWNER.
  - 4.) TW= TOP OF RETAINING WALL, BW= GRADE AT BASE OF WALL.
  - 5.) RETAINING WALL DESIGN WILL BE SUBMITTED TO THE GOVERNING AGENCY.
  - 6.) THE WALL PROFILE INFORMATION IS FOR CONCEPT ONLY. ACTUAL DESIGN OF RETAINING WALL SHALL BE BY A LICENSED PROFESSIONAL ENGINEER & SUBMITTED TO STOCK AND ASSOCIATES FOR GENERAL COMPLIANCE W/ GRADING PLAN.
  - 7.) THE WALL DESIGNER SHALL INCLUDE A "GLOBAL STABILITY ANALYSIS" WITH THE SUBMISSION OF PERMIT PLANS.

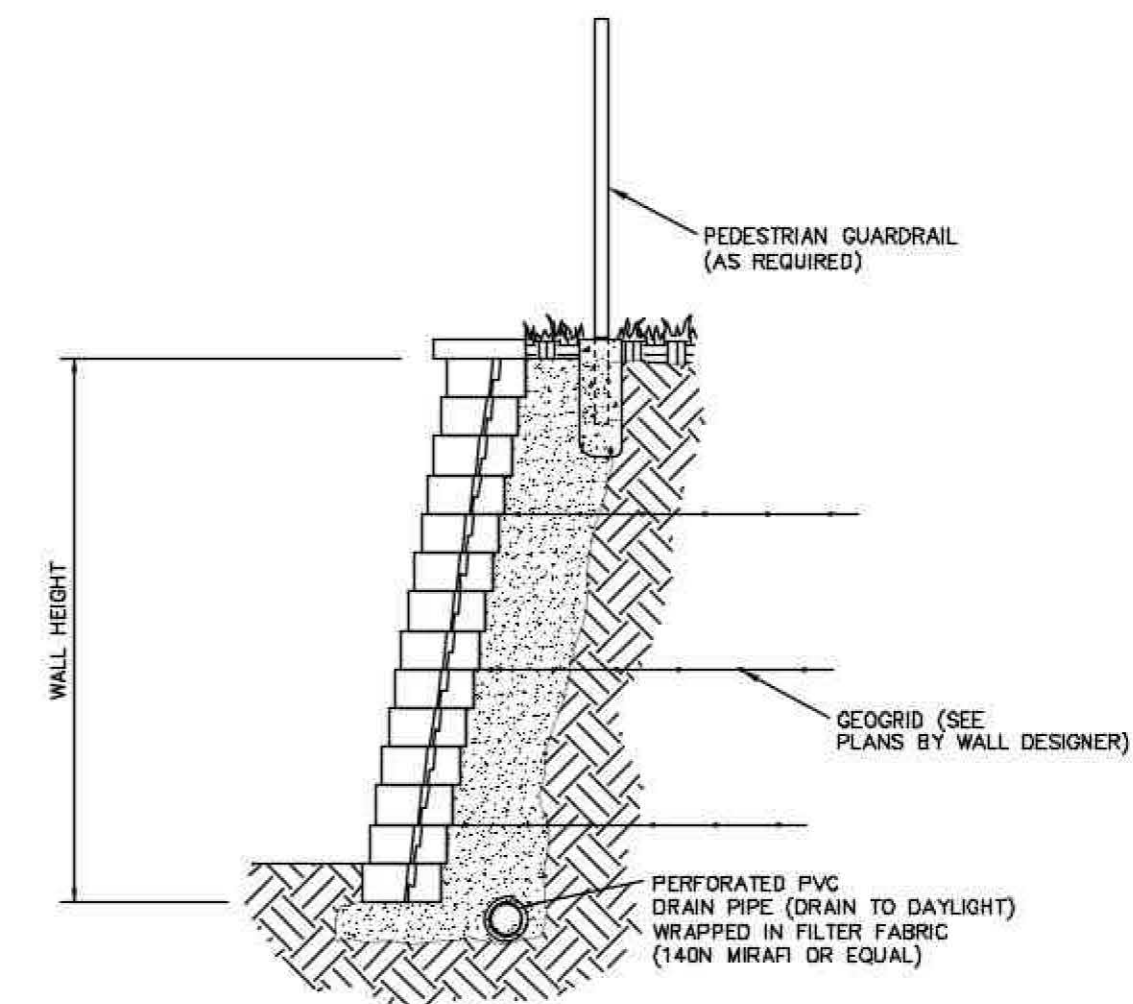

**TYPICAL SECTION**

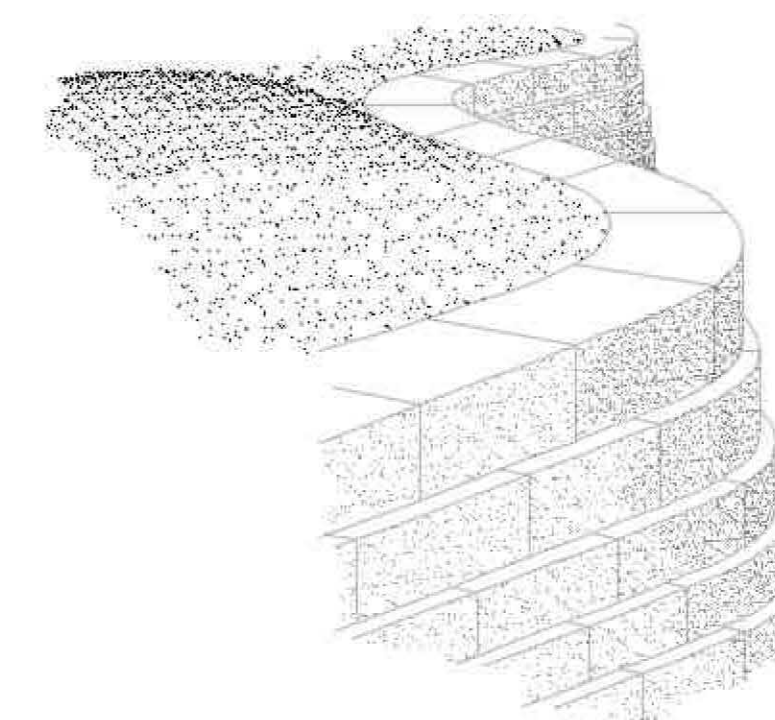

**ISOMETRIC VIEW**

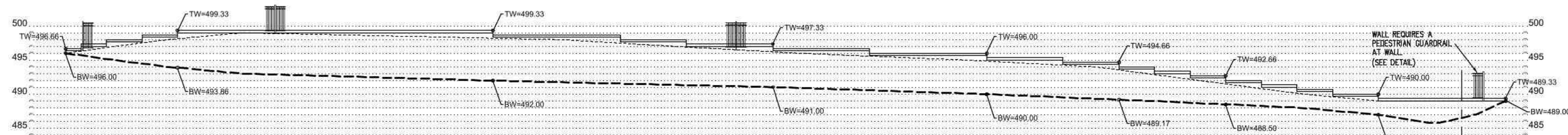

**RETAINING WALL PROFILE**  
SCALE: 1"=10' HORIZONTAL  
1"=10' VERTICAL

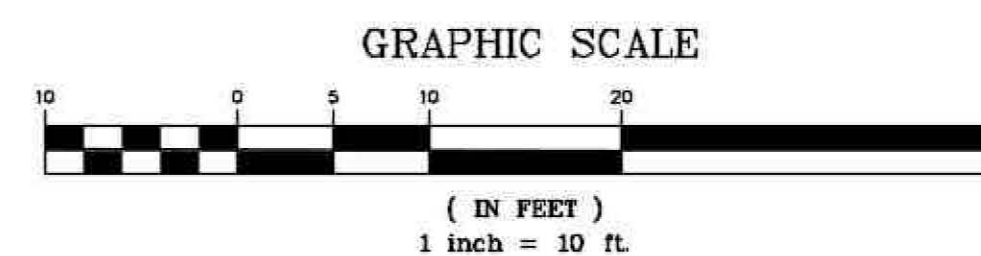
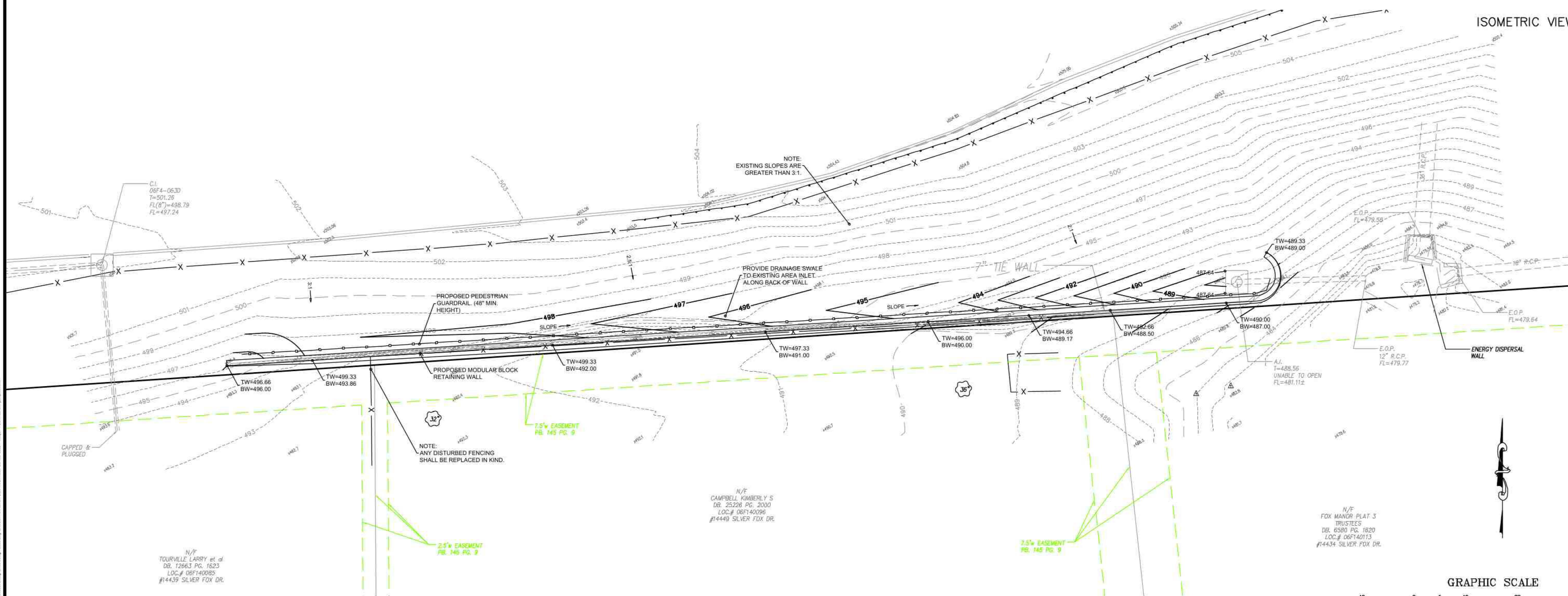

RETAINING WALL REPLACEMENT PLAN FOR:

**JAMESTOWN MALL**  
JAMESTOWN BLVD.  
JAMESTOWN, MISSOURI 63034

DATE:

GEORGE M. STOCK E-25116  
CIVIL ENGINEER  
CERTIFICATE OF AUTHORITY  
NUMBER: 000996

REVISIONS:

DRAWN BY:	J.E.F.	CHECKED BY:	G.M.S.
DATE:	07/18/2022	JOB NO.:	217-6171.2
M.S.D. #:	-	BASE MAP #:	06-F
SLC MAP #:	-	NET SURV. #:	-
M.S.A. #:	-		

SHEET TITLE:  
**PLAN SHEET**

SHEET NO.:

**C1.0**



## EXHIBIT 1

### CONSTRUCTION CONTRACT

This Construction Contract (“Contract”) is made and entered into as of the \_\_\_ day of \_\_\_\_\_, 2023, by and between [\_\_\_\_\_] (“Contractor”), and St. Louis County Port Authority (“Owner”), with respect to the provision by Contractor to Owner of certain labor, materials, equipment and related work and services in connection with repair and replacement of the retaining wall bordering the former Jamestown Mall Site and 14439 Silver Fox Dr., 14449 Silver Fox Dr., and 14434 Silver Fox Dr., located in St. Louis County, Missouri (the “Project”).

1. **Work.** Contractor shall provide and furnish (and as used in this Contract, the term “Work” shall mean) all of the work, labor, supervision, services, materials and equipment necessary that are required by or reasonably inferable from the referenced drawings and specifications attached hereto as **Exhibit A**, including but not limited to the following services:
  - Application and issuance of all necessary permits;
  - Site preparation;
  - Block placement and reinforcement;
  - Wall backfill;
  - Wall drainage;
  - Subsequent protections of wall and fence installation;
  - Grading and re-seeding of the neighboring properties, as necessary; and
  - Re-installment of any prior guardrails and fencing moved or taken down for construction of the wall.

All Work will be performed in a good and workmanlike manner, will be new and in conformance with the requirements of this Contract and all applicable laws, ordinances, and regulations and free from defects in material or workmanship. Contractor shall correct any defects in material or workmanship and any damage to other work or property caused by such defects or the repairing of such defects, at its own expense and without cost to Owner and without interruption to Owner’s occupancy or use of the Work. Contractor shall secure and pay for all necessary building permits and other governmental licenses, approvals and inspections, necessary for the Work, and shall comply with and give all notices required by applicable laws, ordinances, rules, regulations or statutes relating to the performance of the Work

2. **Schedule.** Contractor shall complete the Work required by this Contract no later than \_\_\_ days from the execution of this Contract. Completion requires the proper and full completion of all of the Work so that it is capable of being used for its intended purpose, including but not limited to completion of all punch list items, issuance of all required approvals and certificates, removal of all rubbish, tools, scaffolding and surplus materials from the Site and correction of all property damage that is the responsibility of the Contractor.

3. **Contract Price and Payment.** Except as may be adjusted pursuant to the execution of a written change order by Owner, Owner shall pay Contractor, as full and complete compensation for performance of the Work required by this Agreement, the amounts set forth below (the "Contract Price"), which sum shall be payable as and when provided herein: [CHECK/USE APPROPRIATE BOX(S)]

X a total lump sum price of \$\_\_\_\_\_

the actual cost of labor and materials used to perform the Work, plus a Contractor's fee of [\$\_\_\_\_\_][\_\_\_\_%],

The Contractor's cost and fee shall be subject to a Guaranteed Maximum Price of \$\_\_\_\_\_

Contractor shall submit monthly Applications for Payment to Owner and shall be accompanied by all documentation reasonably requested by Owner and/or necessary to establish that Contractor is entitled to payment of all amounts applied for. Contractor shall provide, with each Application for Payment, a waiver of Contractor's mechanic's lien rights for all labor and material it has provided through Owner's previous payment to Contractor. The Owner shall retain ten (10) percent of the amount of each such payment application until final completion and acceptance of all work covered by this Agreement. Final payment shall be due at such time as the Work is fully completed and all provisions of the Contract have been satisfactorily fulfilled.

4. **Insurance.** Contractor, at Contractor's sole cost and expense, shall carry and maintain the following insurance with companies authorized to do business in the State in which the Project is located and possessing a minimum A.M. Best rating of A-VIII: (a) Commercial General Liability insurance with minimum limits of \$1,000,000 per occurrence, \$2,000,000 aggregate, covering bodily injury liability, personal injury liability and property damage liability, and including contractual liability, products and completed operations coverage; (b) Statutory Worker's Compensation insurance; (c) Employer's Liability insurance with a minimum limit of \$1,000,000 each accident; and (d) Automobile Liability insurance with a minimum limit of \$1,000,000 each accident. Contractor shall submit certificates of all such insurance in duplicate to the Owner prior to the commencement of Work. All policies shall contain a waiver of subrogation against the Owner (if allowed by the Contractor's insurer). **All such general liability policies and the required certificates relating thereto shall name the Owner, Contractor, and neighboring property owners as additional insured, and the certificate holder must be listed as:**

\_\_\_\_\_  
\_\_\_\_\_  
\_\_\_\_\_  
\_\_\_\_\_

5. **Indemnity.** Contractor shall defend, indemnify and hold Owner and all Additional Insureds (including their respective officers and directors), and their agents and employees, harmless from and against any and all claims, damages, losses, liabilities and expenses, including without limitation attorneys fees, arising out of or resulting from the performance of the Work or Contractor's failure to comply with the terms or provisions of the Contract, to the extent in whole or in part by any willful or negligent acts or omissions of Contractor or anyone for whose acts it may be liable. Contractor shall take all necessary precautions to properly protect the Work and the property and work of Owner or any other persons on the Site, from damages caused by the actions of Contractor or any of its Subcontractors. Contractor shall be liable for any loss of, or damage to,

any such property or any injuries to any persons that are caused by the action or neglect of Contractor or any Subcontractors.

6. **Ownership of Documents.** Contractor agrees that all plans, specifications, documents and other information provided in connection with this Contract, whether prepared by Owner or any architect or other designer or engineer involved with the Project, are the property of Owner and shall be held confidential and shall not be used by Contractor for any other purpose or on any other project. The Contractor agrees that Contractor will take reasonable measures to prevent disclosure of such information to any third person and will not use any such information other than on the Owner's behalf, except as the Owner may otherwise authorize in writing.
7. **Assignment and Modification.** Contractor shall not assign, transfer or subcontract any portion or this Contract without the prior written consent of Owner. The Contract represents the entire and integrated agreement between the parties hereto and supersedes all requests for proposals or bids and any responses thereto and all prior negotiations, representations or agreements, either written or oral. No modification, waiver, amendment, discharge or change of this Contract shall be valid unless the same is in writing and signed by the party against which enforcement of such modification, waiver, amendment, discharge or change is or may be sought. This Contract is intended to and shall govern all Work provided by Contractor for the Project, whether initiated or performed prior or subsequent to the execution of this Contract, and the effective date of this Contract shall be deemed to be the first date when any such Work was so provided by Contractor.
8. **Termination.** The Owner may terminate this Contract, with or without cause, upon seven (7) days written notice to the Contractor. In the event the Owner terminates this Contract without cause, the Contractor shall be entitled to compensation only for the Work properly performed by the Contractor, up to and including the date of termination measured by calculating that portion of the Contract Price due to Contractor pursuant to this Contract based on the stage of completion achieved by Contractor as of the date of termination. In the event the Owner terminates this Contract for cause, the Contractor shall be liable to the Owner for (and Owner may deduct from any payments otherwise due to Contractor hereunder) all costs and damages incurred by the Owner as a result of the termination and/or the Contractor's acts, omissions, fault, negligence, errors or breach of contract (including attorney's fees and court costs and the costs of completing the Work).
9. **Review of Project Site.** By executing this Contract, Contractor represents that Contractor has visited the Site, and has become acquainted with all conditions relevant to the performance of the Work. Any variance in actual conditions at the Site from those observed by Contractor prior to the execution of this Contract or contemplated by any of the documents reviewed by or furnished to Contractor shall not be the basis for extra compensation by Owner to Contractor, unless and only to the extent that such variance was not reasonably disclosed to Contractor by such documents or a reasonably thorough visit to the Site.

IN WITNESS WHEREOF, the parties hereto have executed this Contract as of the day and year first above written.

OWNER:

CONTRACTOR:

ST. LOUIS COUNTY PORT AUTHORITY

[Insert name of Contractor]

By: \_\_\_\_\_

By: \_\_\_\_\_

Printed Name: \_\_\_\_\_

Printed Name: \_\_\_\_\_

Title: \_\_\_\_\_

Title: \_\_\_\_\_

**EXHIBIT A**

See attached.

**EXHIBIT 2**

**Bid Proposal**

**ST. LOUIS COUNTY PORT AUTHORITY**

**REPAIR AND REPLACEMENT OF RETAINING WALL BORDERING THE FORMER  
JAMESTOWN MALL PROPERTY IN ST. LOUIS COUNTY**

Bid of \_\_\_\_\_  
(Bidder's Name) (Bidder's Federal I.D. #)

a Corporation or limited liability company organized and existing under the laws of the State of \_\_\_\_\_

or a partnership or joint venture consisting of \_\_\_\_\_

or an individual, trading as \_\_\_\_\_

**F. Bid Proposal Submission:**

The Bidder shall complete and execute this Bid Proposal and enclose it in an envelope that is **sealed** and **clearly marked** with the Bidder's Name, Project Name, and the date of Bid Proposal submission. The Bidder must submit its sealed Bid Proposal to the Owner in accordance with the instructions set forth in the Request for Proposals and Instructions to Bidders.

**B. Bidder:**

All Bidders must be properly registered with and possess valid contractor or trade licenses from all applicable regulatory agencies required to perform the work at the time of submission of this bid. **Time is of the essence for completion of all projects in this package.**

**C. Subcontractors:**

Bidder hereby certifies that the following subcontractors will be used in the performance of the Work. All such subcontractors are subject to Port Authority's approval.

NOTE: Failure to list subcontractors for each category of work identified on the Bid Proposal or the listing of more than one Subcontractor for any category without designating the portion of work to be performed by each may result in rejection of the bid. If the Bidder intends to perform any designated sub-contract work with the use of her or his own employees, she or he shall indicate this in the space below.

**Name and Address of Subcontractors**

**Work to be Performed**

Name: \_\_\_\_\_

\_\_\_\_\_

Address: \_\_\_\_\_

\_\_\_\_\_

\_\_\_\_\_

Name: \_\_\_\_\_

Address: \_\_\_\_\_

\_\_\_\_\_

Name: \_\_\_\_\_

Address: \_\_\_\_\_

\_\_\_\_\_

Name: \_\_\_\_\_

Address: \_\_\_\_\_

\_\_\_\_\_

(Please attach additional sheets if necessary to extend Subcontractor list.)

**E. Price:**

**F.** The undersigned, as Bidder, declares:

- That this Bid Proposal is made, without collusion with any other person, firm or corporation;
- That the Bidder has carefully examined the form of the Contract, Request for Proposals and Instructions to Bidders, Addenda, Specifications, Plans and all other Contract Documents;
- That the Bidder has carefully examined the location, condition and classes of material for the proposed work;
- That the Bidder agrees that it will provide all necessary machinery, tools, apparatus and other means of construction and will do all work and furnish all the materials called for in the Contract Documents in the manner therein prescribed; and
- That this Bid Proposal is submitted inclusive of all costs of insurance and required Bonds

2. In submitting this Bid Proposal, the Bidder agrees:

- That the Owner has the right to reject this Bid Proposal in accordance with the Request for Proposals and Instructions to Bidders.
- To hold the Base Bid Price set forth in this Bid Proposal open for a period of sixty (60) calendar days from the date of the public opening and reading of the Bid Proposals, unless this time period is extended by mutual agreement of the Bidder and the Owner.
- To accomplish the work at the price bid, in accordance with the Contract Documents.



3. Base Bid Price:

- Total amount for the furnishing of all labor, materials, services, equipment and appliances required in conjunction with and properly incidental to all work, in conformance with all Contract Documents. In case of a discrepancy between the amount shown in words and the amount shown in figures, **the amount shown in words shall govern.**

**BASE BID PRICE:**

\_\_\_\_\_

(In Words)

\$ \_\_\_\_\_

(In Figures)

**F.** MBE/WBE Participation:

In accordance with the goals established in the RFP and Instructions to Bidders, the following is Bidder's proposed MBE and WBE participation percentage:

**Aggregate MBE Participation \_\_\_\_\_% of Base Bid**

**Aggregate WBE Participation \_\_\_\_\_% of Base Bid**

As a condition of any Bid Award, Bidder agrees to submit supporting documentation with respect to the above and its efforts to meet Owner's MWBE participation goals within three (3) business days of being notified that it is one of the three (3) apparent low bidders.

**F.** Proposed Schedule:

Bidder proposes to substantially complete the Work for the indicated Bid Price within:

\_\_\_\_\_ **Calendar Days from receipt of a Notice to Proceed (please complete)**

**F.** Addenda:

The Bidder acknowledges receipt and incorporated into this bid of the following Addenda:

Number: \_\_\_\_\_

Dated: \_\_\_\_\_

## **F. CERTIFICATION**

**The Bidder hereby certifies to the best of its knowledge and belief and under penalty of perjury under the laws of the United States and the State of Missouri:**

1. That all information provided herein is accurate and truthful.
2. That an affirmative action program of equal employment opportunity, in accordance with the requirements of Missouri Law and 41 CFR 60-1.4(b), has been adopted by this organization to ensure that applicants are employed and employees are treated without regard to their race, creed, color, national origin, ancestry, marital status, sex, or affectional or sexual orientation, and that the selection and utilization of contractors, subcontractors, consultants, materials suppliers and equipment lessors shall be done without regard to their race, creed, color, national origin, ancestry, marital status, sex, or affectional or sexual orientation. Such action shall include but not be limited to the following: employment, upgrading, demotion or transfer, recruitment or recruitment advertising, layoff or termination, rates of pay or other forms of compensation, and selection for training, including apprenticeships. The Bidder agrees to post in conspicuous places, available to employees and applicants for employment, Notices to be provided by the Owner setting forth provisions of this nondiscrimination clause. Said affirmative action program addresses both the internal recruitment, employment and utilization of minorities and the external recruitment policy regarding minority contractors, subcontractors, consultants, materials suppliers and equipment lessors.
3. That Bidder has and will comply with and adhere to the provisions of the Copeland Anti-Kickback Act (18 USC 874) as Supplemented in Department of Labor regulations (29 CFR, Part 3), that the enclosed bid is genuine and not collusive or sham; that Bidder has not colluded, conspired, connived or agreed, directly or indirectly, with any other bidder or person, to put in a sham bid or to refrain from bidding, and has not in any manner, directly or indirectly, sought by agreement, collusion, communication, conference, or otherwise, with any person, to fix the bid price of Bidder or of any other bidder, or to fix any overhead, profit or cost element of said bid price, or of that of any other bidder, or to secure any advantage against any person interested in the proposed contract; and that all statements in said proposal of bid are true and that the prices quoted in the enclosed bid are fair and proper and not tainted by any collusion, conspiracy and connivance and place responsibility on, in addition to the Bidder, its agents, representatives, owners, employees, or parties of interest.
4. That Bidder and its contractors will use its best efforts to provide a preference for the purchase, acquisition, and use of goods, products, materials, etc. produced within the United States, in the performance of this Agreement pursuant to 2 CFR §200.322.
5. That Bidder must comply with Section 6002 of the Solid Waste Disposal Act, as amended by the Resource Conservation and Recovery Act. The requirements of Section 6002 include procuring only items designated in guidelines of the Environmental Protection Agency (EPA) at 40 CFR, 247 that contain the highest percentage of recovered materials practicable, consistent with maintaining a satisfactory level of competition where the purchase price exceeds \$10,000 or the value of the quantity acquired by the preceding fiscal year exceeded \$10,000, procuring solid waste

management services in a manner that maximizes energy and resource recovery, and establishing an affirmative procurement program for procurement of recovered materials identified in EPA guidelines.

6. Bidder will follow all environmental requirements, which includes the Clean Air Act (42 U.S.C.A. §7401 et seq.) (“CAA”); Federal Water Pollution Control Act and amendments (33 U.S.C.A. §1251 et seq.) (“Clean Water Act” or “CWA”); and regulations, rules, guidelines, or standards promulgated pursuant to such laws, statute and regulations, as such statutes, regulations, rules, guidelines, and standards, as amended from time to time.
7. Bidder will comply with 40 U.S.C. 3702 and 3704, as supplemented by Department of Labor regulations (29 CFR Part 5). Under 40 U.S.C. 3702 of the Act, Bidder must be required to compute the wages of every mechanic and laborer on the basis of a standard work week of 40 hours. Work in excess of the standard work week is permissible provided that the worker is compensated at a rate of not less than one and a half times the basic rate of pay for all hours worked in excess of 40 hours in the work week. The requirements of 40 U.S.C. 3704 are applicable to construction work and provide that no laborer or mechanic must be required to work in surroundings or under working conditions which are unsanitary, hazardous or dangerous. These requirements do not apply to the purchases of supplies or materials or articles ordinarily available on the open market, or contracts for transportation or transmission of intelligence.
8. Bidder will comply with the Davis Bacon Act and Title VI of the Civil Rights Act of 1964 as codified in 42 U.S.C. §2000d et seq.
9. Bidder agrees that it is not using telecommunications and video surveillance equipment and services as prohibited by 2 CFR §200.216 and §200.471.
10. That neither the Bidder nor its principals:
  - A. are currently debarred, suspended, proposed for debarment, declared ineligible, or voluntarily excluded from bidding or contracting by any agency of government including but not limited to federal, state, regional, county or local government agency, in this or any other state including any department, division, commission, authority, office, branch, section and political subdivision or other governmental or quasi-governmental entity;
  - B. have, within a three-year period preceding this bid, been convicted or had a civil judgment rendered against them for commission of fraud or a criminal offense in connection with obtaining, attempting to obtain or performing a public federal, state or local contract; violation of federal or state antitrust statutes or commission of

embezzlement, theft, forgery, bribery, falsification or destruction of records, making false statements, or receiving stolen property;

- C. are currently indicted for or otherwise criminally or civilly charged by a governmental entity (federal, state or local) with commission of any of the offenses enumerated in paragraph (B) of this certification; and
  - D. have, within a three-year period preceding this bid, had one or more public contracts (federal, state or local) terminated for cause or default.
11. The Bidder has current, valid contractor or trade licenses and permits required under applicable Missouri law for any trade or specialty area in which the firm seeks to perform work.
12. During the term of construction of the project(s) that comprise this package, the Bidder will have in place a suitable quality control and quality assurance program and an appropriate safety and health plan.
- 13. Where the Bidder is unable to certify to any of the statements in this certification, the Bidder shall explain below.**

---

---

*[Signature Page on Following Page]*

**IN WITNESS WHEREOF, the Bidder has caused this instrument to be signed, attested to and sealed.**

Bidder: \_\_\_\_\_  
(Legal Firm Name)

By: \_\_\_\_\_  
(Signature) \_\_\_\_\_  
(Printed or Typed Name)

Title: \_\_\_\_\_

Address: \_\_\_\_\_  
\_\_\_\_\_

Telephone No.: \_\_\_\_\_

Fax No.: \_\_\_\_\_

Date: \_\_\_\_\_

STATE OF MISSOURI        )  
  ) SS  
COUNTY OF ST. LOUIS    )

Subscribed and sworn to before me this \_\_\_\_\_ day of \_\_\_\_\_, 2020.

\_\_\_\_\_  
Notary Public

My commission expires:

**END OF BID PROPOSAL**

**EXHIBIT 3**

**PREVAILING WAGE ORDER**

See attached.

# Missouri

## Division of Labor Standards

### WAGE AND HOUR SECTION



MICHAEL L. PARSON, Governor

# Annual Wage Order No. 29

Section 100  
**ST. LOUIS COUNTY**

In accordance with Section 290.262 RSMo 2000, within thirty (30) days after a certified copy of this Annual Wage Order has been filed with the Secretary of State as indicated below, any person who may be affected by this Annual Wage Order may object by filing an objection in triplicate with the Labor and Industrial Relations Commission, P.O. Box 599, Jefferson City, MO 65102-0599. Such objections must set forth in writing the specific grounds of objection. Each objection shall certify that a copy has been furnished to the Division of Labor Standards, P.O. Box 449, Jefferson City, MO 65102-0449 pursuant to 8 CSR 20-5.010(1). A certified copy of the Annual Wage Order has been filed with the Secretary of State of Missouri.

Original Signed by \_\_\_\_\_

Todd Smith, Director  
Division of Labor Standards

Filed With Secretary of State: \_\_\_\_\_ **March 10, 2022**

Last Date Objections May Be Filed: **April 11, 2022**

Prepared by Missouri Department of Labor and Industrial Relations

OCCUPATIONAL TITLE	**Prevailing Hourly Rate
Asbestos Worker	\$65.45
Boilermaker	\$39.32*
Bricklayer	\$60.54
Carpenter	\$58.58
Lather	
Linoleum Layer	
Millwright	
Pile Driver	
Cement Mason	\$54.43
Plasterer	
Communications Technician	\$59.45
Electrician (Inside Wireman)	\$71.06
Electrician Outside Lineman	\$68.45
Lineman Operator	
Lineman - Tree Trimmer	
Groundman	
Groundman - Tree Trimmer	
Elevator Constructor	\$91.46
Glazier	\$65.02
Ironworker	\$65.54
Laborer	\$51.36
General Laborer	
First Semi-Skilled	
Second Semi-Skilled	
Mason	\$49.84
Marble Mason	
Marble Finisher	
Terrazzo Worker	
Terrazzo Finisher	
Tile Setter	
Tile Finisher	
Operating Engineer	\$65.26
Group I	
Group II	
Group III	
Group III-A	
Group IV	
Group V	
Painter	\$42.45
Plumber	\$73.66
Pipe Fitter	
Roofer	\$54.64
Sheet Metal Worker	\$69.85
Sprinkler Fitter	\$76.83
Truck Driver	\$39.32*
Truck Control Service Driver	
Group I	
Group II	
Group III	
Group IV	

\*The Division of Labor Standards received fewer than 1,000 reportable hours for this occupational title. The public works contracting minimum wage is established for this occupational title using data provided by Missouri Economic Research and Information Center.

\*\*The Prevailing Hourly Rate includes any applicable fringe benefit amounts for each occupational title as defined in Section 290.210 RSMo.



Heavy Construction Rates for  
ST. LOUIS County

OCCUPATIONAL TITLE	**Prevailing Hourly Rate
Carpenter	\$60.73
Millwright	
Pile Driver	
Electrician (Outside Lineman)	\$68.45
Lineman Operator	
Lineman - Tree Trimmer	
Groundman	
Groundman - Tree Trimmer	
Laborer	\$51.58
General Laborer	
Skilled Laborer	
Operating Engineer	\$66.22
Group I	
Group II	
Group III	
Group IV	
Truck Driver	\$49.97
Truck Control Service Driver	
Group I	
Group II	
Group III	
Group IV	

Use Heavy Construction Rates on Highway and Heavy construction in accordance with the classifications of construction work established in 8 CSR 30-3.040(3).

Use Building Construction Rates on Building construction in accordance with the classifications of construction work established in 8 CSR 30-3.040(2).

If a worker is performing work on a heavy construction project within an occupational title that is not listed on the Heavy Construction Rate Sheet, use the rate for that occupational title as shown on the Building Construction Rate Sheet.

\*The Division of Labor Standards received fewer than 1,000 reportable hours for this occupational title. The public works contracting minimum wage is established for this occupational title using data provided by Missouri Economic Research and Information Center.

\*\*The Prevailing Hourly Rate includes any applicable fringe benefit amounts for each occupational title as defined in Section 290.210 RSMo.

# OVERTIME and HOLIDAYS

## OVERTIME

For all work performed on a Sunday or a holiday, not less than twice (2x) the prevailing hourly rate of wages for work of a similar character in the locality in which the work is performed or the public works contracting minimum wage, whichever is applicable, shall be paid to all workers employed by or on behalf of any public body engaged in the construction of public works, exclusive of maintenance work.

For all overtime work performed, not less than one and one-half (1½) the prevailing hourly rate of wages for work of a similar character in the locality in which the work is performed or the public works contracting minimum wage, whichever is applicable, shall be paid to all workers employed by or on behalf of any public body engaged in the construction of public works, exclusive of maintenance work or contractual obligation. For purposes of this subdivision, "**overtime work**" shall include work that exceeds ten hours in one day and work in excess of forty hours in one calendar week; and

A thirty-minute lunch period on each calendar day shall be allowed for each worker on a public works project, provided that such time shall not be considered as time worked.

## HOLIDAYS

January first;  
The last Monday in May;  
July fourth;  
The first Monday in September;  
November eleventh;  
The fourth Thursday in November; and  
December twenty-fifth;

If any holiday falls on a Sunday, the following Monday shall be considered a holiday.